

## Mega Vac Commercial Vacuum Operation and Maintenance



Made in America

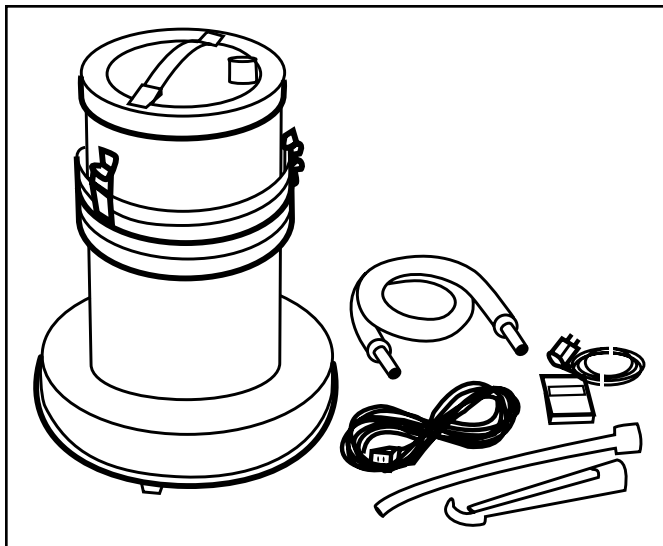


Figure 1: The Mega Vac, Item 35851

### Description

The Menda 35851 Mega Vac is a high capacity, high performance, service vacuum. This model has been specifically designed with large clean-up jobs in mind. The powerful by-pass motor can handle almost any job. It was designed for those technicians who require a large, mobile vacuum for use in and around sensitive electronic equipment such as copy centers, telecom centers, rechargers, garages, refiners, shops, and schools. The standard 0.3 micron filter canister is ideal for dust, glass, pollens, soot, drywall dust, brake dust, toner, and other fine particles. The optional .12 micron HEPA filter canister is suitable for lead and other ultra-fine particles. The filters are fully contained for safe, easy disposal.

The Mega Vac is safe for ESD susceptible electronics. The 10' long hose and the utensils are static dissipative. The internal ground-wire in the flex-hose and enclosure, virtually eliminate static charge generation from the utensils. Any charge generated is safely dissipated back through the electrically grounded motor.

**Note:** The Menda Mega Vac is designed for commercial use only.

### Inspection:

Remove the Mega Vac from the shipping carton and inspect for exterior damage.

### Items included with model 35851:

- 1 0.3 Micron 5 Gallon Filter Canister
- 1 10' Flex-Hose (Toner Proof and Static Dissipative)
- 1 Goose Neck Attachment
- 1 Crevice Attachment
- 1 Crevice Attachment Brush
- 1 Detachable Power Cord (110V Only)
- 1 Base With Easy Rollers
- 1 Foot Switch

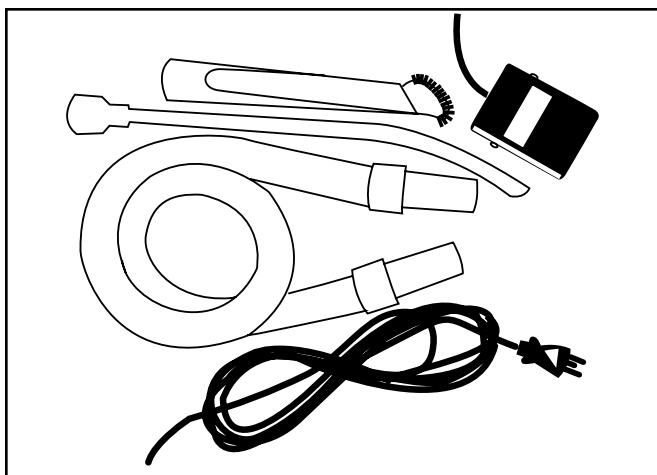


Figure 2: Items included with Model 35851

### Optional Accessories

- 35858 Replacement 0.3 Micron Filter Canister
- 35859 Replacement .12 Micron HEPA Filter Canister

### Operation

Place the vacuum head onto the filter canister by inserting the white down tube into the corresponding size hole in the filter canister (fig. 3). Align the rubber retaining clips with the corresponding chrome retainer latches on the vacuum head and stretch into place (fig. 4). Place the head and canister into the mobile base. Insert either end of the flex hose into the knurled aluminum receptacle on the top of the vacuum head (fig. 5).

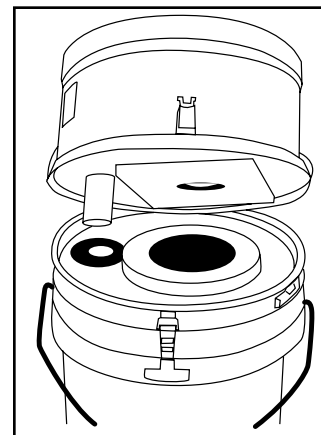
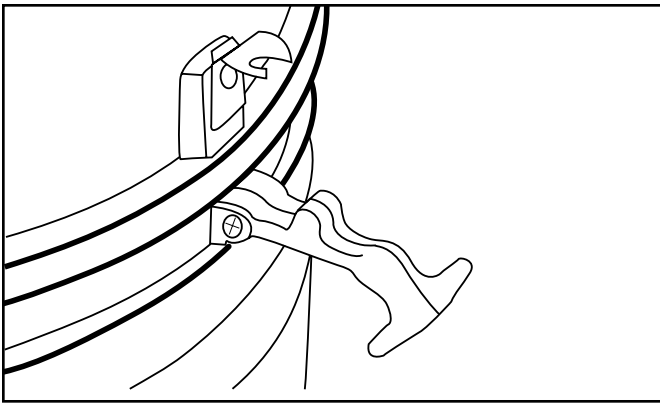


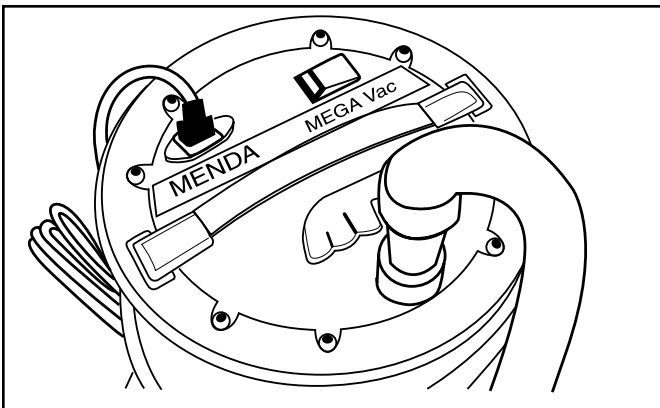
Figure 3: Aligning down tube

3651 Walnut Avenue, Chino, CA 91710

Phone: (909) 627-2453 • Fax (909) 755-8848 • Web Site: [www.mendapump.com](http://www.mendapump.com)

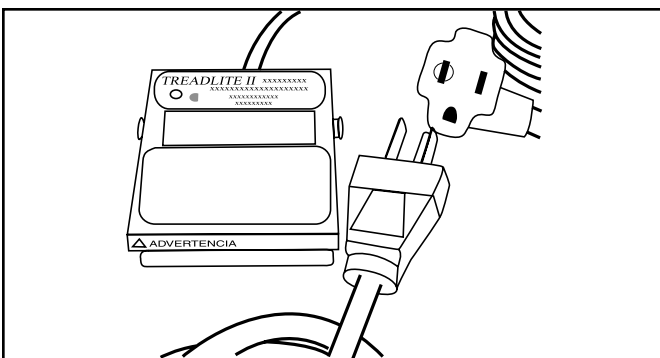


**Figure 4:** Align retaining clips



**Figure 5:** Insert hose into receptacle

Insert the female end of the power cord into the power receptacle on the vacuum head. Plug the power cord into an electrical outlet that is properly grounded in accordance with all local codes and ordinances. The power switch is located on the top of the vacuum head. Select an appropriate attachment for the job and the Mega Vac is now ready to operate.



**Figure 6:** Using foot switch

### Foot Switch Operation

Unplug the Mega Vac from the power source. Leave the standard power cord plugged into the receptacle on the vacuum head. Plug the male end of the power cord into

the female end of the foot switch power cord, and the male end into the 120 VAC electrical receptacle. You are now ready for footswitch operation.

### Filter Change-Out Instructions

Remove the power cord from the electrical power source. Unfasten the rubber retaining clips from the vacuum head and filter canister. Lift the vacuum head from the filter canister and set aside. Place the filter canister lid securely on the filter and dispose of in a proper manner. Place the vacuum head on the new filter making sure to align the rubber retaining clips with the retaining latches. If they do not line up properly, unsnap the metal band latch on the filter and rotate the band until they lineup, then secure the band.

### Limited Warranty

Menda expressly warrants that for a period of one (1) year from the date of purchase, Menda Mega Vacs will be free of defects in material (parts) and workmanship (labor). Within the warranty period, the product will be tested, repaired, or replaced at Menda's option, free of charge. Call our Customer Service Department at 909-627-2453 for a Return Material Authorization (RMA) and proper shipping instructions and address. Include a copy of your original packing slip, invoice, or other proof of purchase date. Any unit under warranty should be shipped prepaid to the Menda factory. Warranty repairs will take approximately two weeks.

If your unit is out of warranty, call Customer Service at 909-627-2453 for a Return Material Authorization (RMA) and proper shipping instructions and address. Menda will quote repair charges necessary to bring your unit up to factory standards.

### Warranty Exclusions

THE FOREGOING EXPRESS WARRANTY IS MADE IN LIEU OF ALL OTHER PRODUCT WARRANTIES, EXPRESSED AND IMPLIED, INCLUDING MERCHANTABILITY AND FITNESS FOR A PARTICULAR PURPOSE WHICH ARE SPECIFICALLY DISCLAIMED. The express warranty will not apply to defects or damage due to accidents, neglect, misuse, alterations, operator error, or failure to properly maintain, clean or repair products.

### Limit of Liability

In no event will Menda or any seller be responsible or liable for any injury, loss or damage, direct or consequential, arising out of the use of or the inability to use the product. Before using, users shall determine the suitability of the product for their intended use, and users assume all risk and liability whatsoever in connection therewith.

3651 Walnut Avenue, Chino, CA 91710

Phone: (909) 627-2453 • Fax (909) 755-8848 • Web Site: [www.mendapump.com](http://www.mendapump.com)